

REBLOC RB100-8

Standard element

Installation

Free standing

H4b

W6



Containment level

H4b (covers H3, H2, H1, N1, T3, T2 and T1)

Working width

W6 (covers W7 and W8)

Impact severity level

ASI B

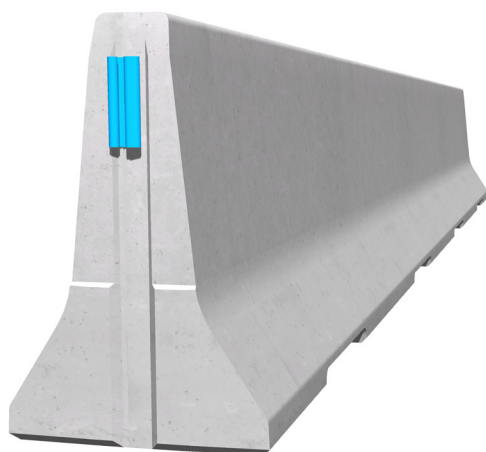

Precast concrete vehicle restraint systems are used for long lasting protection on the central reservation and along the verge. Vehicles deviating from the road are retained or redirected and prevent a dangerous breakthrough onto the opposite carriageway.

The integrated, innovative coupling does not contain any loose parts. This does not only enhance the safety, but also the installation speed. The easy installation, which does not depend on weather conditions, reduces the disruptions of the traffic flow.

Thanks to the interlocking construction, there are no loose parts, which prevent unauthorized removal of pieces and protects fully against vandalism.

REBLOC RB100-8

Standard element

H4b

W6

Technical data

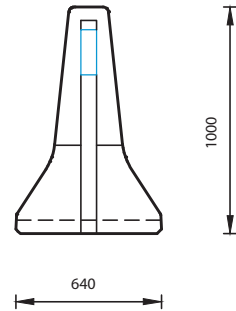
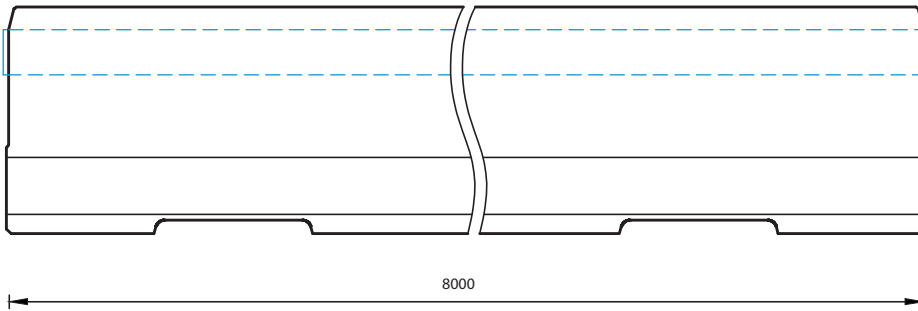

all dimensions in mm

Containment level	H4b
Working width	W6
Impact severity level	ASI B
Vehicle intrusion	VI9
Installation	free standing on asphalt/concrete
Terminal elements	REBLOC 100-4T (4 x M24 adhesive anchor)
Dimensions L x W x H in mm	8000 x 640 x 1000 mm
Weight/element (approx.)	6000 kg
Elements/truck (24 t)	4 elements
Minimum installation length	104 m
Curve radius	$r \geq 108$ m, smaller radii in combination with REBLOC 100-4, REBLOC 100-3 and REBLOC 100-2
Coupling/exposed steel parts	fully integrated, exposed parts hot-dip galvanized
CE certification	✓

System element - combinable

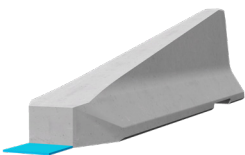

Terminal element
REBLOC 100-4T
(inclination 1:5)