

REBLOC RB110L-8

Standard element

Installation

Free standing

H2

W5



Containment level **H2** (covers H1, N1, T3, T2 and T1)
 Working width **W5** (covers W6, W7 and W8)
 Impact severity level **ASI B**

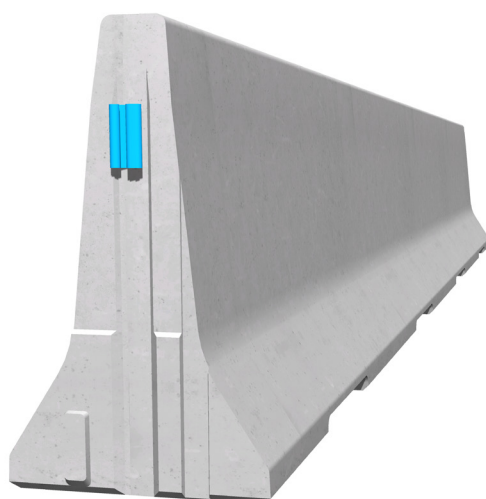

Precast concrete vehicle restraint systems are used for long lasting protection on the central reservation and along the verge. Vehicles deviating from the road are retained or redirected and prevent a dangerous breakthrough onto the opposite carriageway. As a result road users and persons as well as objects at the roadside are well protected.

In addition to the safety of road users, priorities in the development of our systems are also economic efficiency and return on investment. In addition, a long life as well as low environmental impact are important product features. As with all REBLOC® products, the 110L-8 has the integrated coupling, which guarantees a high protection against breakthrough and the elements can be quickly connected to each other.

REBLOC RB110L-8

Standard element

H2

W5

Technical data

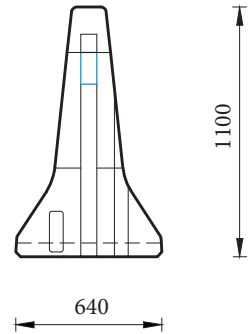
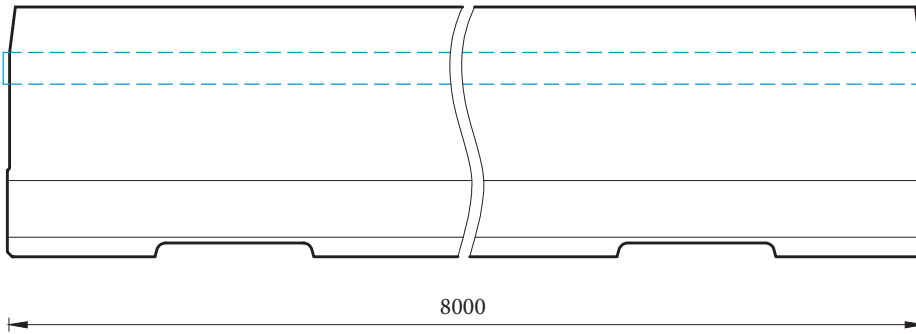

all dimensions in mm

Containment level	H2
Working width	W5
Impact severity level	ASI B
Vehicle intrusion	VI4
Installation	free standing on asphalt/concrete
Terminal elements	required; REBLOC 110L-4.5T (4 x M24 adhesive anchor)
Dimensions L x W x H in mm	8000 x 640 x 1100 mm
Weight/element (approx.)	6000 kg
Elements/truck (24 t)	4 elements
Minimum installation length	80 m (not including terminal elements)
Curve radius	$r \geq 265$ m, smaller radii in comb. with REBLOC 110L-4 and REBLOC 110L-2
Coupling/exposed steel parts	fully integrated, exposed parts hot-dip galvanized
CE certification	✓

System element - combinable

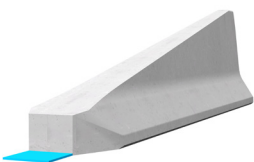

Terminal element
REBLOC 110L-4.5T
(inclination 1:5)

2

 0115 983 2304

 sales@hardstaffbarriers.com

 A Division of Hill & Smith Ltd, Hillside, Gotham Road,
Kingston-on-Soar, Nottingham, NG11 0DF