

REBLOC RB120Q-8

Standard element

H4b

W6

Installation

Free standing



Containment level

H4b (covers H3, H2, H1, N1, T3, T2 and T1)

Working width

W6 (covers W7 and W8)

Impact severity level

ASI B

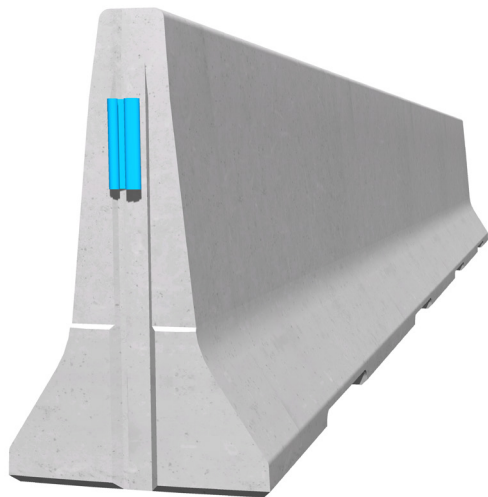

Precast concrete vehicle restraint systems are used for long lasting protection on the central reservation and along the verge. Vehicles deviating from the road are retained or redirected and prevent a dangerous breakthrough onto the opposite carriageway.

In addition to the safety of road users, priorities in the development of our systems are also economic efficiency and return on investment. In addition, a long life as well as low environmental impact are important product features. As with all REBLOC® products, the REBLOC 120Q-8 has the integrated coupling, which guarantees a high protection against breakthrough and the elements can be quickly connected to each other.

0115 983 2304

sales@hardstaffbarriers.com | enquiries@hardstaffbarriers.com

A Division of Hill & Smith Ltd, Hillside, Gotham Road,
Kingston-on-Soar, Nottingham, NG11 0DF

REBLOC RB120Q_8

Standard element

H4b

W6

Technical data

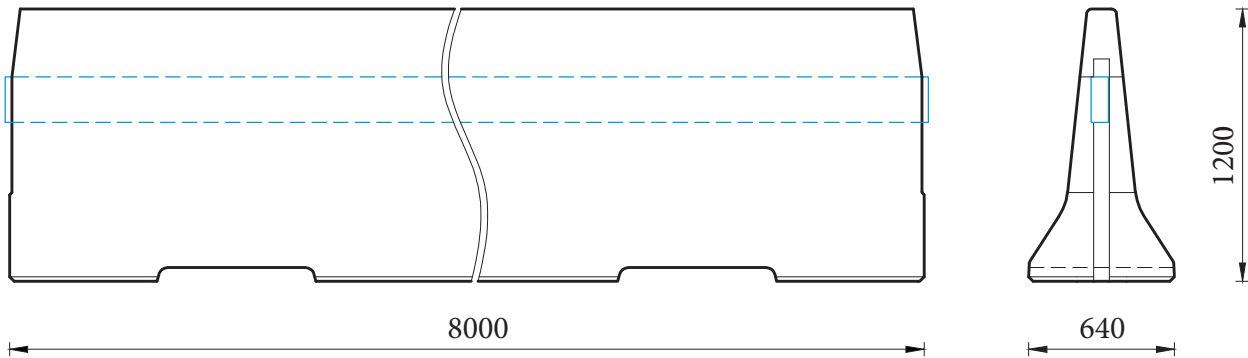

all dimensions in mm

Containment level	H4b
Working width	W6
Impact severity level	ASI B
Vehicle intrusion	VI4
Installation	free standing on asphalt/concrete
Terminal elements	required; REBLOC 120Q-5T (4 x M24 adhesive anchor)
Dimensions L x W x H in mm	8000 x 640 x 1200 mm
Weight/element	6260 kg
Elements/truck (24 t)	3 elements
Minimum installation length	104 m (not including terminal elements)
Curve radius	$r \geq 108$ m
Coupling/exposed steel parts	fully integrated, exposed parts hot-dip galvanized
CE certification	✓

System element - combinable

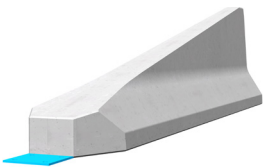

Terminal element
REBLOC 120Q-5T
(inclination 1:5)