

REBLOC RB84XEA.3-8

Standard element

Installation
Embedded



Containment level	H2 (covers H1, N1, T3, T2, T1)
Working width	W1 (covers W2, W3, W4, W5, W6, W7, W8)
Impact severity level	ASI B

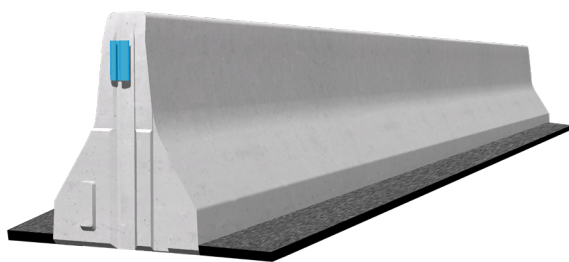

The vehicle restraint system 84XEA.3-8 is embedded 40mm in asphalt or concrete and is mainly used, where a high containment level is needed within a narrow space.

The installation of short barrier sections is possible due to a short minimum installation length. The system is also available with drainage openings.

The integrated, innovative coupling does not contain any loose parts. This does not only enhance the safety, but also the installation speed. The easy installation, which does not depend on weather conditions, reduces the disruptions of the traffic flow.

Thanks to the interlocking coupling, there are no loose parts, which prevent unauthorized removal of pieces and protects fully against vandalism.

REBLOC RB84XE.3-8

Standard element

H2

W1

Technical data

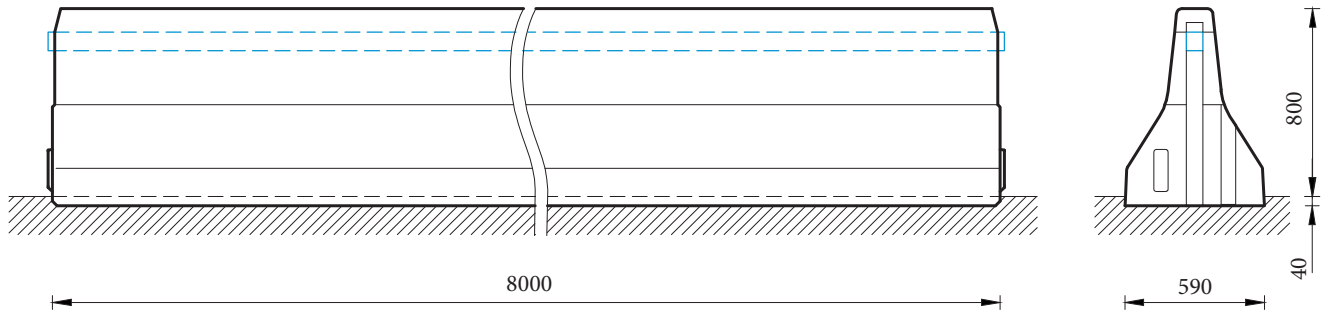

all dimensions in mm

Containment level	H2
Working width	W1
Impact severity level	ASI B
Vehicle intrusion	VI3
Installation	40 mm embedded in asphalt/concrete
Terminal elements	not necessary, optional available
Dimensions L x W x H in mm	8000 x 590 x 840 mm
Weight/element (approx.)	4600 kg
Elements/truck (24 t)	5 elements
Minimum installation length	32 m
Curve radius	$r \geq 260$ m, smaller radii on request
Coupling/exposed steel parts	fully integrated, exposed parts hot-dip galvanized
CE certification	✓